

MATERIAL: STAINLESS STEEL 440C, HARDENED TO Rc 58 MIN

REV	ECO NO.	ECO TITLE	DATE
02	-----	DRAWING UPDATE	06/08/14

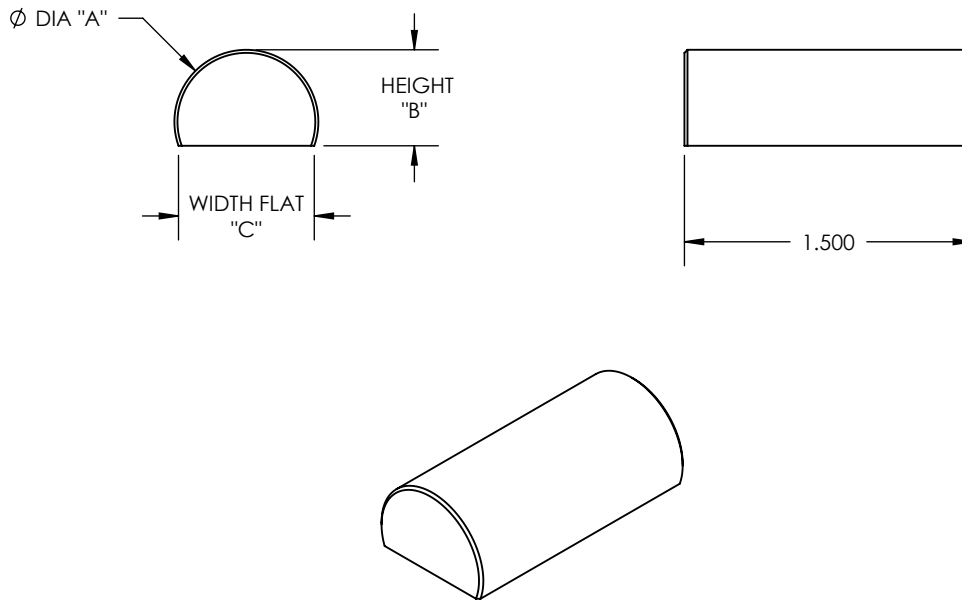

PART NUMBER	DIAMETER "A"	HEIGHT "B"	WIDTH FLAT "C"
250-TC	0.250 ± .0001	0.167 ± .002	0.235
312-TC	0.3125 ± .0001	0.208 ± .002	0.294
375-TC	0.375 ± .0001	0.250 ± .002	0.353
500-TC	0.500 ± .0001	0.334 ± .002	0.471
750-TC	0.750 ± .0001	0.500 ± .002	0.707
100-TC	1.000 ± .0001	0.750 ± .002	0.866

<p><b>PROPRIETARY INFORMATION</b></p> <p>THE INFORMATION CONTAINED IN THIS DRAWING IS THE SOLE PROPERTY OF MICRO SURFACE ENGR. INC. AND IS FURNISHED FOR INFORMATIONAL PURPOSES ONLY.</p> <p>© 2006 MICRO SURFACE ENGR. INC.</p>	<p>UNLESS OTHERWISE SPECIFIED:</p> <p>DIMENSIONS ARE IN INCHES</p> <p>TOLERANCES:            ANGULAR: 1°            TWO PLACE DECIMAL ±.01            THREE PLACE DECIMAL ±.005</p> <p>INTERPRET GEOMETRIC TOLERANCING PER: ANSI Y14.5</p>	 <p><b>Bal-tec</b><sup>TM</sup>            1550 E. SLAUSON AVE            LOS ANGELES, CA 90011</p>	TITLE		NUMBER	REV
			TRUNCATED CYLINDER		SEE TABLE	02
			ENGINEER	DWN BY	DATE DRAWN	SIZE
GENE GLEASON	BLC	06/08/14	A	1:1	1 OF 1	